

# HYDRAULIC MOTOR CABLE REEL

● Protective structure ..... IP54

## Model description

### CRD-8A9L-OM10

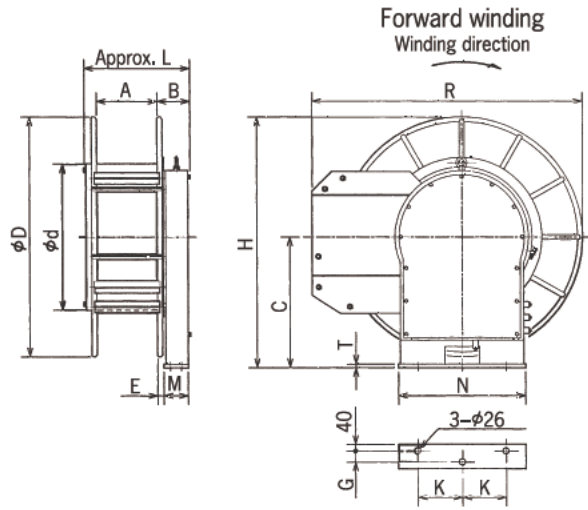
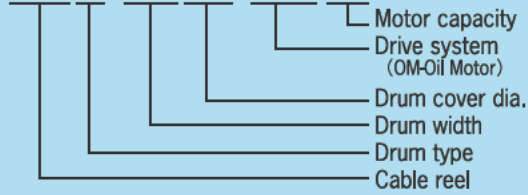

## Dimensions (Rated voltage AC600)

Model	Dimensions (mm)															Mass (kg)
	D	d	A	B	C	H	L	R	E	G	K	M	N	T		
CRD-8A9L-OM10 150A×4P	1100	670	306	119	620	1170	499	1230	37	50	200	120	580	16	270	
CRD-8A10L-OM12 150A×4P	1250	670	306	119	650	1275	499	1380	37	50	200	120	580	16	280	
CRD-8LA11L-OM20 200A×4P	1500	750	306	170	780	1530	550	1615	39	140	220	200	630	16	310	

NOTE: 1.No upside down setting is allowed.  
2.For any special requirements, please contact us.

## Max operational cable length (Mobile application/Horizontal retrieve)

(units: mm)

Model	Type	Size	Weight	Outside dia.	3PNCT	2PNCT	3PNCT	3PNCT	2PNCT	3PNCT	3PNCT	
					3PNCT	2PNCT	3PNCT	3PNCT	2PNCT	3PNCT	3PNCT	
CRD-8A9L-OM10 150A×4P		22mm <sup>2</sup> ×4C	2.07kg/m	φ 35	100	100	80					
CRD-8A10L-OM12 150A×4P		38mm <sup>2</sup> ×4C	2.55kg/m	φ 35	130	130	110	80				
CRD-8LA11L-OM20 200A×4P		38/14mm <sup>2</sup> ×3/1C	2.54kg/m	φ 38				120	100	90	60	
		38mm <sup>2</sup> ×4C	3.02kg/m	φ 41								
		60mm <sup>2</sup> ×4C	4.02kg/m	φ 44								
		50/14mm <sup>2</sup> ×3/1C	3.18kg/m	φ 48								
		60mm <sup>2</sup> ×4C	4.69kg/m	φ 51								

## Conditions

- Operating the hydraulic motor to forward and reverse make the cable wind and payout.
- When manual operation, please take into consideration of bypass circuit for hydraulic circuit.
- And brake type needs to release the brake to payout cable.

Without brake type

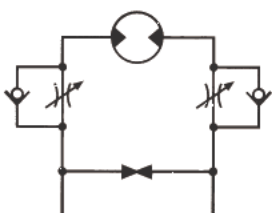

With brake type

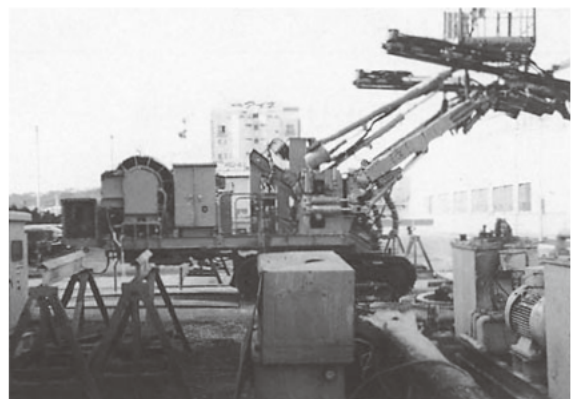
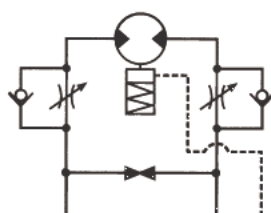

- Cable reel without brake requires the cable fall-prevention construction
- Motor brake applies external pilot systems. (Braking release pressure is over 1MPa.)